



## RYOBI COMPOUND MITER SAW



### SAFETY RULES

- **Know your power tool.**
- **Guard against electrical shock by preventing body contact with grounded surfaces.**
- **Keep guards in place.**
- **Keep work areas clean.** Cluttered areas invite accidents.
- **Avoid dangerous environments.** Don't use power tools in damp or wet locations. Do not expose power tools to rain. Keep work area well lit.
- **Avoid gaseous areas.** Do not operate portable electric tools in explosive atmospheres in presence of flammable liquids or gases. Motors in these tools normally spark, and the sparks might ignite fumes.
- **Keep children away.** Do not let visitors contact tool or extension cord.
- **Never leave tool running unattended. Turn the power off.**
- **Keep tool dry, clean and free from oil and grease.**
- **Be sure blade path is free of nails.**
- **Never touch blade during use.**
- **Guard against electric shock.** Prevent body contact with grounded surfaces like pipes, radiators, ranges, and refrigerator enclosures. Rubber gloves and non-skid footwear are recommended when working outdoors, where damp or wet ground may be encountered.
- **Dress properly.** Do not wear loose clothing or jewelry. They can be caught in moving parts. Wear protective hair covering to contain long hair.
- **Use safety equipment. Wear safety goggles** or glasses with side shields. Wear hearing protection during extended use of power tools and dust mask for dusty operations.
- **Stay alert. Use common sense.** Watch what you are doing. Do not operate tool when you are tired or under influence of drugs.
- **Remove adjusting keys and wrenches.** Form habit of checking keys and adjusting wrenches before turning it on.
- **Avoid accidental starting.** Don't carry plugged in tool with finger on switch. Be sure switch is OFF when plugged in.
- **Don't overreach.** Keep proper footing and balance at all times.
- **Before connecting the tool** to power source, be sure voltage supplied is the same as that specified on the nameplate of the tool. If in doubt, DO NOT plug in tool. A power source with voltage greater than that

specified for the tool can result in serious injury to the user—as well as damage to the tool. Using a power source with voltage less than the nameplate rating is harmful to the motor.

### **TOOL USE AND CARE**

- **Don't force tool.** It will do the job better and safer at the rate for which it was designed.
- **Use the right tool.** Don't use tool for purpose not intended
- **Secure work.** Use clamps or a vise to hold work. It's safer than using your hand and it frees both hands to operate the tool.
- **Don't abuse cord.** Never carry tool by cord or yank it to disconnect from receptacle. Keep cord from spinning blade, bits or any other moving part while the tool is in use.
- **Outdoor use extension cords.** When tool is used outdoors, use only extension cords suitable for use outdoors.
- **Disconnect tools** when not in use; before servicing; when changing blades, bits, cutters, etc.
- **Do not alter or misuse tool.** These tools are precision built. Any alteration or modification not specified may result in a dangerous condition.
- **Check damaged parts.** Check damaged parts. Before further use of the tool, a guard or other part that is damaged should be carefully checked to determine that it will operate properly and perform its intended function. Check for alignment of moving parts, binding of moving parts, breakage of parts, mounting, and any other conditions that may affect its operation.

### **SAFETY RULES FOR MITER SAWS**

- **Firmly clamp or bolt** your tool to a workbench or table at approximately hip height.
- **Keep hands away from cutting area and blade.** Do not reach underneath work or in blade cutting path with your hands and fingers for any reason. Always turn the power off.
- **Always support long workpieces** while cutting to minimize risk of blade pinching and kickback. Saw may slip, walk or slide while cutting long or heavy boards.
- **Always use a clamp** to secure the workpiece when possible.
- **Be sure the blade clears the workpiece.** Never start the saw with the blade touching the workpiece. Allow motor to come up to full speed before starting cut.
- **Never** cut more than one piece at a time. **Do NOT** stack more than one workpiece on the saw table at a time.
- **Make sure the miter table and saw arm (bevel function) are locked in position before operating your saw.**
- **Never use a length stop on the free scrap end of a clamped workpiece.** Never hold onto or bind the free scrap end of the workpiece in any operation.
- **Never perform any operation freehand.** Always place the workpiece to be cut on the miter table and position it firmly against the fence as a backstop. Always use the fence.
- **Never** hand hold a workpiece that is too small to be clamped. Keep hand clear of the cutting area.
- **Never** move the workpiece or make adjustment to any cutting angle while the saw is running and the blade is rotating. Any slip can result in contact with the blade causing serious personal injury.
- **Keep your body positioned to either side of the saw blade, but not in line with the saw blade.** Kickback could cause the saw to jump backwards.
- **Always** release the power switch and allow the saw blade to stop rotating before raising it out of the workpiece.
- **Do not turn the motor switch on and off rapidly.**
- **Make sure the work area has ample lighting** to see the work and that no obstructions will interfere with safe operation **before** performing any work using the saw.
- **Always turn off the saw** before disconnecting it to avoid accidental starting when reconnecting to power supply. **Never** leave the saw unattended while connected to a power source.
- **Turn off tool** and wait for saw blade to come to a complete stop before moving workpiece or changing settings.
- **This tool** should have the following markings:
  - a) Wear eye protection.
  - b) Keep hands out of path of saw blade.

- c) Do not operate saw without guards in place.
- d) Do not perform any operation freehand.
- e) Never reach around saw blade.
- f) Turn off tool and wait for saw blade to stop before moving workpiece or changing settings.
- g) Disconnect power (or unplug tool as applicable) before changing blade or servicing.
- h) No load speed.
- **Avoid** direct eye exposure when using the laser guide.
- **This saw can tip over** if the saw head is released suddenly and the saw is not secured to a work surface. **Always** secure this saw to a stable work surface before any use to avoid serious personal injury.

## **GLOSSARY OF TERMS**

### **Anit-Kickback Pawls (radial arm and table saws)**

A device which, when properly installed and maintained, is designed to stop the workpiece from being kicked back toward the front of the saw during a ripping operation.

### **Arbor**

The shaft on which a blade or cutting tool is mounted.

### **Bevel Cut**

A cutting operation made with the blade at any angle other than 90° to the table surface.

### **Chamfer**

A cut removing a wedge from a block so the end (or part of the end) is angled rather than at 90°.

### **Compound Cut**

A cross cut made with both miter and a bevel angle.

### **Cross Cut**

A cutting or shaping operation made across the grain or the width of the workpiece.

### **Cutter Head (planer & jointers)**

A rotating piece of adjustable blades. The cutter head removes material from the workpiece.

### **Dado Cut**

A non-through cut which produces a square-sided notch or trough in the workpiece.

### **Featherboard**

A device used to help control the workpiece by guiding it securely against the table or fence during any ripping operation.

### **FPM or SPM**

Feet per minute (or strokes per minute), used in reference to blade movement.

### **Freehand**

Performing a cut without the workpiece being guided by a fence, miter gauge, or other aids.

### **Gum**

A sticky, sap-based residue from wood.

### **Heel**

Alignment of the blade to the fence.

### **Kerf**

The material removed by the blade in a through cut or the slot produced by the blade in a non-through or partial cut.

**Kickback**

A hazard that can occur when the blade binds or stalls, throwing the workpiece back toward operator.

**Leading End**

The end of the workpiece pushed into the tool first.

**Miter Cut**

A cutting operation made with the workpiece at any angle to the blade other than 90°.

**Non-Through Cuts**

Any cutting operation where the blade does not extend completely through the thickness of the workpiece.

**Push Blocks and Push Sticks**

Devices used to feed the workpiece through the saw blade during cutting operations. A push stick (not a push block) should be used for narrow ripping operations. These aids help keep the operator's hands well away from the blade.

**Resaw**

A cutting operation to reduce the thickness of the work-piece to make thinner pieces.

**Resin**

A sticky, sap-based substance that has hardened.

**Revolutions Per Minute (RPM)**

The number of turn completed by a spinning object in one minute.

**Ripping or Rip Cut**

A cutting operation along the length of the workpiece.

**Riving Knife (table saws)**

Also know as a spreader or splitter. A metal piece, slightly thinner than the saw blade, which helps keep the kerf open and also helps to prevent kickback.

**Saw Blade Path**

The area over, under, behind, or in front of the blade. As it applies to the workpiece, that area which will be or has been cut by the blade.

**Set**

The distance that the tip of the saw blade tooth is bent (or set) outward from the face of the blade.

**Snipe (planers)**

Depression made at either end of a workpiece by cutter blades when the workpiece is not properly supported.

**Throw-Back**

The throwing back of a workpiece usually caused by the workpiece being dropped into the blade or being placed inadvertently in contact with the blade.

**Through Sawing**

Any cutting operation where the blade extends completely through the thickness of the workpiece.

**Workpiece or Material**

The item on which the operation is being done.

**Worktable**

Surface where the workpiece rests while performing a cutting, drilling, planing, or sanding operation.

**KNOW YOUR COMPOUND MITER SAW**

The safe use of this product requires an understanding of the information on the tool and in this operator's manual as well as a knowledge of the project you are attempting. Before use of this product, familiarize yourself with all operating features and safety rules.

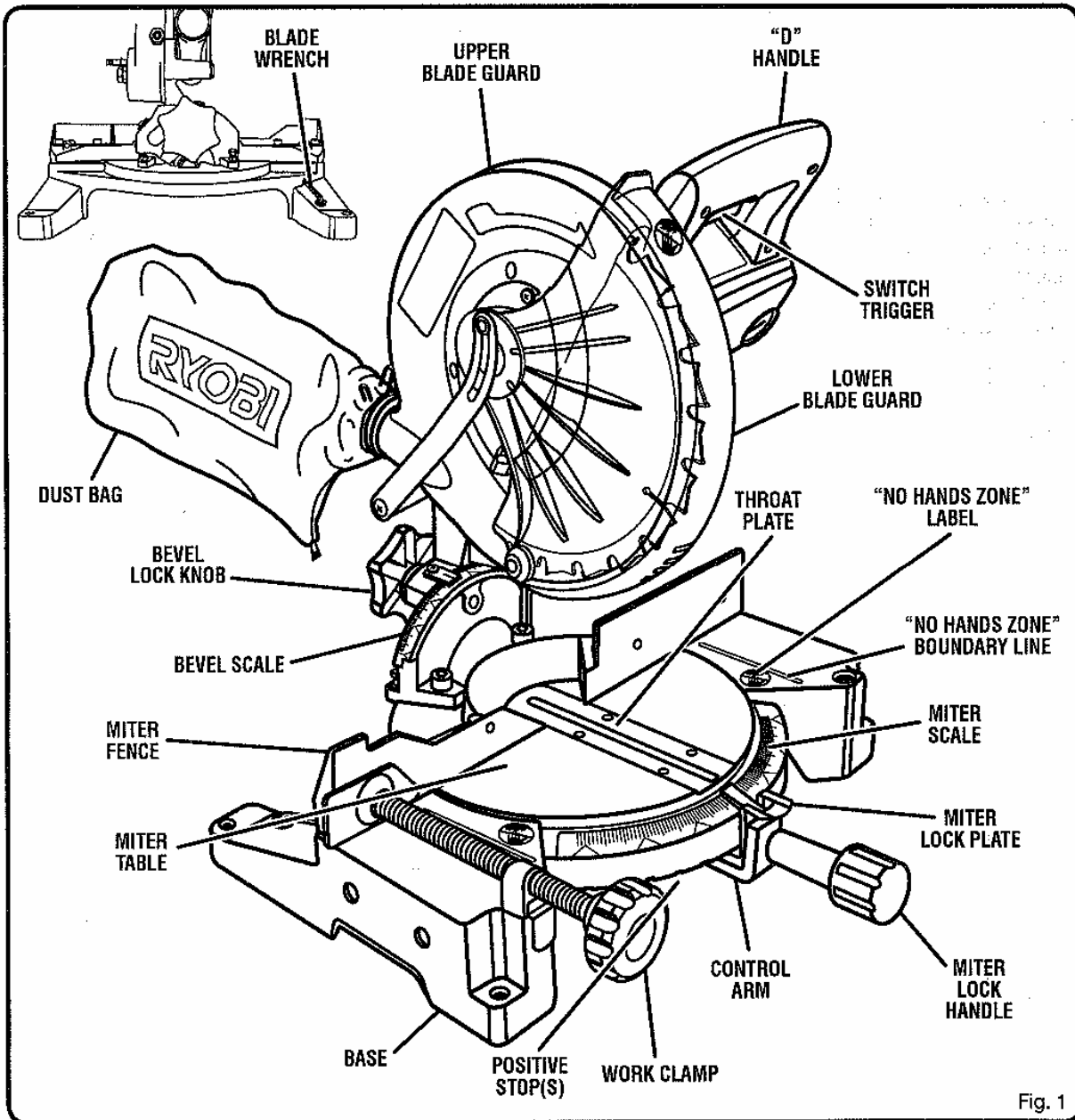

**10 in. Blade**

A 10 in. blade is included with the compound miter saw. It will cut materials up to 2 in. thick or 6 in. wide, depending upon the angle at which the cut is being made.

### **Bevel Lock Knob**

The bevel lock knob securely locks the compound miter saw at desired bevel angles. Positive stop adjustment screws have been provided on each side of the saw arm. These adjustment screws are for making fine adjustments at 0° and 45°.

### **Blade Wrench Storage**

See Figure 1.

A blade wrench is packed with the saw. One end of the wrench is a Phillips screwdriver and the other end is a hex key. Use the hex key end when installing or removing blade and the Phillips end when removing or loosening screws. A storage area for the blade wrench is located in the saw's base.

### **Carrying The Saw**

Located on each side of the base are two recessed areas for carrying the saw. From behind the saw with the saw in the locked down position, grasp the base in the recessed area to move the miter saw.

### **Electric Brake**

An electric brake has been provided to quickly stop blade rotation after the switch is released.

### **Laser Guide**

For more accurate cuts, a laser guide is included with your miter saw. When used properly, the laser guide makes accurate, precision cutting simple and easy.

### **Miter Fence**

The miter fence on the compound miter saw has been provided to hold the workpiece securely against when making all cuts. The left side is also larger providing additional support.

### **Miter Lock Handle**

The miter lock handle securely locks the saw at desired miter angles.

### **Positive Stops On Miter Table**

Positive stops have been provided at 0°, 15°, 22-1/2°, 30°, and 45°. The 22-1/2° and 45° positive stops have been provided on both the left and right side of the miter table.

### **Self-Retracting Lower Blade Guard**

The lower blade guard is made of shock-resistant, see-through plastic that provides protection from each side of the blade. It retracts over the upper blade guard as the saw is lowered into the workpiece.

### **Spindle Lock Button**

The spindle lock button locks the spindle stopping the blade from rotating. Depress and hold the lock button while installing, changing, or removing blade.

### **Switch Trigger**

To prevent unauthorized use of the saw, disconnect it from the power supply and lock the switch in the off position. To lock the switch, install a padlock (not included) through the hole in the switch trigger.

### **OPERATION**

**Warning:** Do not allow familiarity with tools to make you careless. Remember that a careless fraction of a second is sufficient to inflict serious injury.

**Warning:** Always wear safety goggles or safety glasses with side shields when operating power tools. Failure to do so could result in objects being thrown into your eyes resulting in possible serious injury.

**Warning:** Do not use any attachments or accessories not recommended by the manufacturer of this tool. The type of use can result in serious personal injury.

### **Applications**

You may use this tool for the following purposes:

- Crosscutting wood and plastic
- Crosscutting miters, joints, etc. for picture frames molding, door casings, and fine joinery.
- Bevel cutting and compound cutting
- **Note:** The blade provided is fine for most wood cutting operations, but for fine joinery cuts or cutting plastic, use one of the accessory blades available from the Ryobi dealer.

**Warning:** Before starting any cutting operation, clamp or bolt the compound miter saw to a workbench. Never operate the miter saw on the floor or in a crouched position. Failure to heed this warning can result in serious personal injury.

**Warning:** To avoid serious personal injury, always tighten the miter lock handle securely before making a cut. Failure to do so could result in movement of the control arm or miter table while making a cut.

**Warning:** To avoid serious personal injury, keep hands outside the no hands zone, at least 3 in. from blade. Never perform any cutting operation freehand (without holding workpiece against the fence). The blade could grab the workpiece if it slips or twists.

### **Cutting With Your Compound Miter Saw**

**Warning:** When using a clamp to secure the workpiece, clamp workpiece on one side of the blade only. The workpiece must remain free on one side of the blade to prevent the blade from binding in workpiece. The workpiece binding the blade will cause motor stalling and kickback. This situation could cause an accident resulting in possible serious personal injury.

**Warning:** NEVER move the workpiece or make adjustment to any cutting angle while the saw is running and the blade is rotating. Any slip can result in contact with the blade causing serious personal injury.

### **To Crosscut**

See Figure 25

A crosscut is made by cutting across the grain of the work-piece. A straight crosscut is made with the miter table set at the 0° position. Miter crosscuts are made with the miter table set at some angle other than zero.

- Pull out the lock pin and lift saw arm to its full height.
- Loosen the miter lock handle. Rotate the miter lock handle approximately one-half turn to the left to loosen.
- Press the miter lock plate down with thumb and hold.
- Rotate the control arm until the pointer aligns with the desired angle on the miter scale.
- Release the miter lock plate.
- Tighten the miter lock handle securely.
- Place the workpiece flat on the miter table with one edge securely against the fence. If the board is warped, place the convex side against the fence. If the concave edge of a board is placed against the fence, the board could collapse on the blade at the end of the cut, jamming the blade.
- When cutting long pieces of lumber or molding, support the opposite end of the stock with a roller stand or with a work surface level with the saw table.
- Align cutting line on workpiece with edge of saw blade.
- Grasp the stock firmly with one hand and secure it against the fence. Use the optional work clamp or a C-clamp to secure the workpiece when possible.

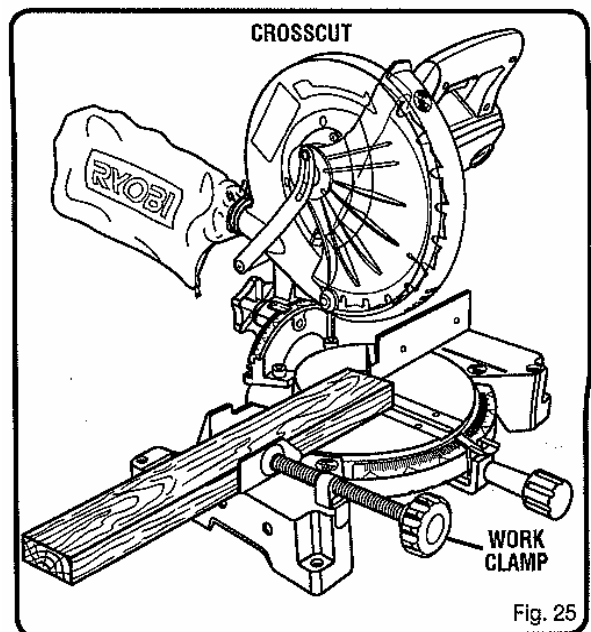

- Before turning on the saw, perform a dry run of the cutting operation just to make sure that no problems will occur when the cut is made.
- Grasp the “D” handle firmly then squeeze the switch trigger. Allow several seconds for the blade to reach maximum speed.
- Slowly lower the blade into and through the workpiece.
- Release the switch trigger and allow the blade to stop rotating before raising the blade out of workpiece. Wait until the electric brake stops blade from turning before removing the workpiece from the miter table.

### To Bevel Cut

See Figures 26-27

- Pull out the lock pin and lift saw arm to its full height.
- Loosen the miter lock handle. Rotate the miter lock handle approximately one-half turn to the left to loosen.
- Press the miter lock plate down with thumb and hold.
- Rotate the control arm until the pointer aligns with zero on the miter scale.
- Release the miter lock plate.
- Tighten the miter lock handle securely.
- The 45 triangle on the miter fence provides for the maximum clearance required for adjusting the miter saw’s angle when making a bevel or compound cut.
- Grasp the stock firmly with one hand and secure it against the fence. Use the optional work clamp or a C-clamp to secure the workpiece when possible.
- Before turning on the saw, perform a dry run of the cutting operation just to make sure that no problems will occur when the cut is made.
- Grasp the “D” handle firmly then squeeze the switch trigger. Allow several seconds for the blade to reach maximum speed.
- Slowly lower the blade into and through the workpiece.
- Release the switch trigger and allow the saw blade to stop rotating before raising the blade out of workpiece. Wait until the electric brake stops blade from turning before removing the workpiece from miter table.

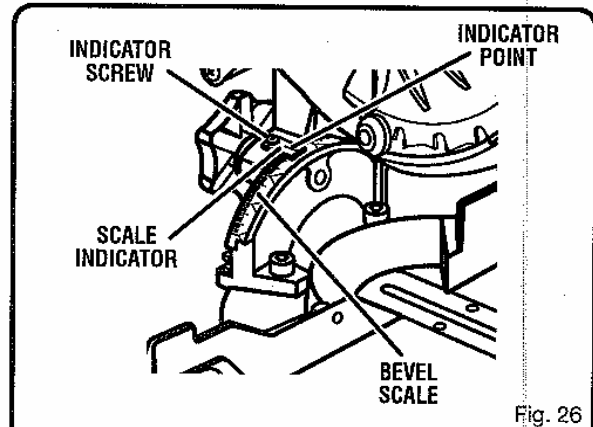

Fig. 26

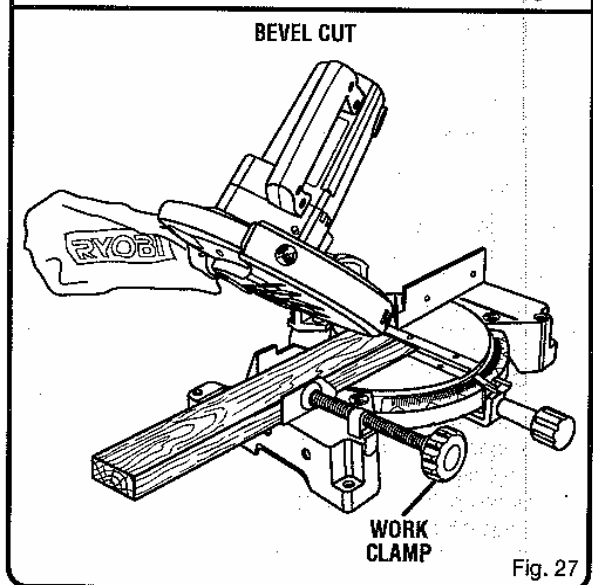

Fig. 27

### To Compound Miter Cut

A compound miter cut is a cut made using a miter angle and a bevel angle at the same time. This type of cut is used to make picture frames, cut molding, make boxes with sloping sides, and for certain roof framing cuts.

To make this type of cut the control arm on the miter table must be rotated to the correct angle and the saw arm must be tilted to the correct bevel angle. Care should always be taken when making compound miter setups due to the interaction of the two angle settings.

Adjustments of miter and bevel settings are interdependent with one another. Each time you adjust the miter setting you change the effect of the bevel setting. Also, each time you adjust the bevel setting you change the effect of the miter setting.

It may take several settings to obtain the desired cut. The first angle setting should be checked after setting the second angle, since adjusting the second angle affects the first.

Once the two correct settings for a particular cut have been obtained, always make a test cut in scrap material before making a finish cut in good material.

- Pull out the lock pin and lift saw arm to its full height.
- Loosen the miter lock handle. Rotate the miter lock handle approximately one-half turn to the left to loosen.
- Press the miter lock plate down with your thumb and hold.
- Rotate the control arm until the pointer aligns with the desired angle on the miter scale.
- Release the miter lock plate.
- Tighten the miter lock handle securely.
- Loosen the bevel lock knob and move the saw arm to the left to the desired bevel angle.
- Bevel angles can be set from 0° to 45°.
- Once the saw arm has been set at the desired angle, securely tighten the bevel lock knob.
- Recheck miter angle setting. Make a test cut in scrap material.
- Place the workpiece flat on the miter table with one edge securely against the fence. If the board is warped, place the convex side against the fence. If the concave edge of a board could collapse on the blade at the end of the cut, jamming the blade.
- When cutting long pieces of lumber or molding, support the opposite end of the stock with a roller stand or with a work surface level with the saw table.
- Align the cutting line on the workpiece with the edge of saw blade.
- Grasp the stock firmly with one hand and secure it against the fence. Use the optional work clamp or a C-clamp to secure the workpiece when possible.
- Before turning on the saw, perform a dry run of the cutting operation just to make sure that no problems will occur when the cut is made.
- Grasp the "D" handle firmly then squeeze the switch trigger. Allow several seconds for the blade to reach maximum speed.
- Slowly lower the blade into and through the workpiece.
- Release the switch trigger and allow the saw blade to stop rotating before raising the blade out of workpiece. Wait until the electric brake stops blade from turning before removing the workpiece from miter table.

### **To Support Long Workpieces**

Long workpieces need extra supports. Supports should be placed along the workpiece so it does not sag. The support should let the workpiece lay flat on the base of the saw and work table during the cutting operation. Use the optional work clamp or a C-clamp to secure the workpiece.

### **Cutting Crown Molding**

The compound miter saw does an excellent job of cutting crown molding. In general, compound miter saws do a better job of cutting crown molding than any other tool made.

In order to fit properly, crown molding must be compound mitered with extreme accuracy. The two contact surfaces on a piece of crown molding that fit flat against the ceiling and the wall of a room are at angles that, when added together, equal exactly 90°. Most crown molding has a top rear angle (the section that fits flat against the ceiling) of 52°.and a bottom rear angle (the section that fits flat against the wall) of 38°.

### **Laying Molding Flat On The Miter Table**

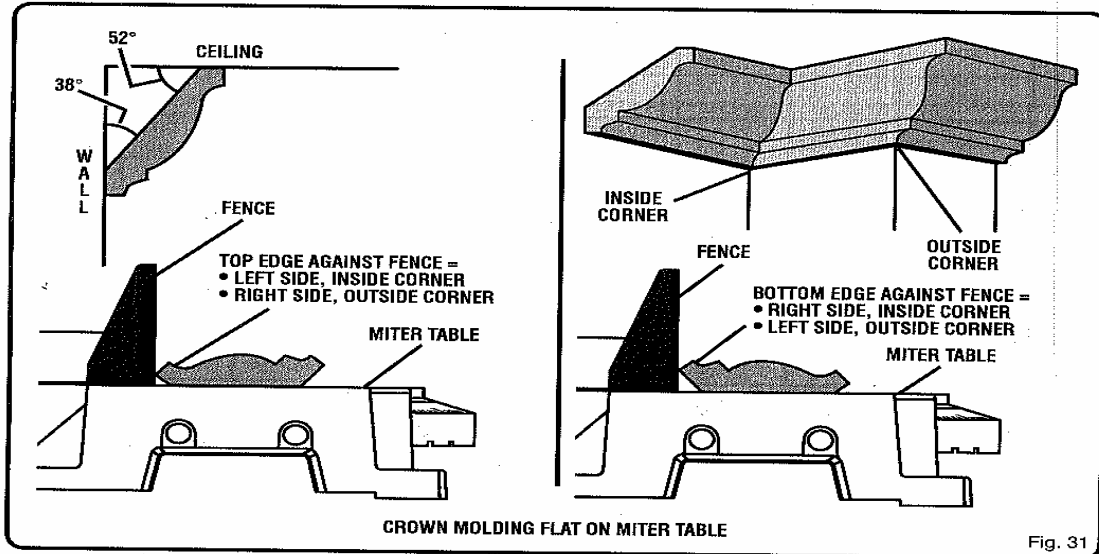

To use this method for accurately cutting crown molding for a 90° inside or outside corner, lay the molding with its broad back surface flat on the miter table and against the fence.

When setting the bevel and miter angles for compound miters, remember that the settings are interdependent; changing one angle changes the other angle as well.

Keep in mind that the angles for crown moldings are very precise and difficult to set. Since it is very easy for these angles to shift, all settings should first be tested on scrap molding. Also most walls do not have angles of exactly 90°, therefore, you will need to fine tune your settings.

When cutting crown molding by this method the bevel angle should be set at 33.85° either right or left, depending on the desired cut for the application. See the chart below for correct angle settings and correct positioning of crown molding on miter table.

The setting in the chart below can be used for cutting all standard (US) crown molding with 52° and 38° angles. The crown molding is placed flat on the miter table using the compound features of your miter saw.

Bevel Angle Setting	Type of Cut
33.85°	<b>Left side, inside corner</b> 1. Top edge of molding against fence 2. Miter table set right 31.62° 3. Save left end of cut
33.85°	<b>Right side, inside corner</b> 1. Bottom edge of molding against fence 2. Miter table set left 31.62° 3. Save left end of cut
33.85°	<b>Left side, outside corner</b> 1. Bottom edge of molding against fence 2. Miter table set left 31.62° 3. Save right end of cut
33.85°	<b>Right side, outside corner</b> 1. Top edge of molding against fence 2. Miter table set right 31.62° 3. Save right end of cut

### Cutting Warped Material

When cutting warped material, always make sure it is positioned on the miter table with the convex side against the fence as shown in figure 32.

If the warped material is positioned the wrong way as shown in figure 33, it will pinch the blade near the completion of the cut.

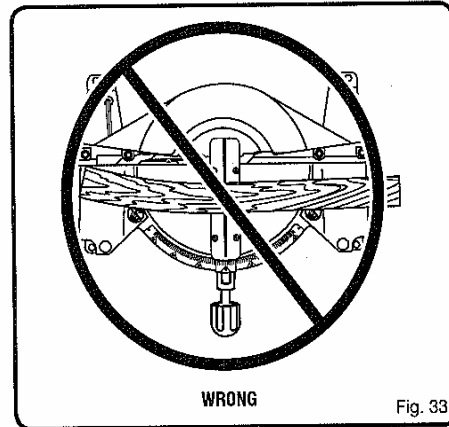
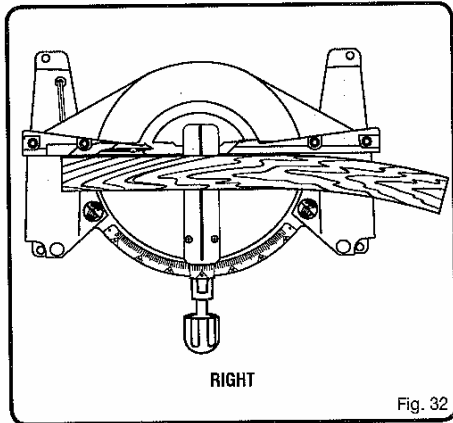

**Warning:** To avoid kickback and to avoid serious personal injury, never position the concave edge of bowed or warped material against the fence.

### Clamping Wide Workpieces

When cutting wide workpieces, such as 2 in x 6 in boards, clamp with a C-clamp as shown in figure 34.

